



**CHANCE RIDES MANUFACTURING, INC.**  
**4200 Walker**  
**Wichita, KS 67277-2328**  
**U.S.A.**  
Phone: 1-316-942-7411 • FAX: 1-316-942-2012  
**Website: [www.chancerides.com](http://www.chancerides.com)**  
**E-mail: [rides@chancerides.com](mailto:rides@chancerides.com)**

Bulletin No:	B402CRM201-0
Release Date:	July 6, 2017
Effective Date:	July 6, 2017
Supersedes:	A402R1129-0 (Chance Rides, Inc., 6/25/93)
Completion Date:	See Text
Page:	1 of 3

# SERVICE BULLETIN

Ride Manufacturer: CHANCE RIDES, INC.

Affected Production Dates: All

Ride Name: WIPEOUT

Affected Serial Nos.: All Units

Model No.: 402

**Abstract of Issue:**

**Boom Pivot Inspection and Maintenance**

**Reason For Release:**

This bulletin supersedes Chance Rides, Inc. Service Bulletin B402R1129-0. This bulletin updates and supplements the information contained in B408R1129-0.

The boom pivot on the WIPEOUT amusement ride is assembled with two special pins. Specific fasteners are required to secure the pins. If the fasteners become loose, the pins can start to back out of the boom-to-turret joint. Damage to the ride and/or injury to passengers and personnel can result.

It is essential for the care of the equipment and safety of the passengers that the boom pivot is properly assembled, maintained and inspected. This bulletin is being released to emphasize and detail the proper components as well as their inspection and maintenance.

**Action to be Taken:**

Chance Rides, Inc. requires all owner/operators of the above noted amusement rides to immediately perform the inspection described in the bulletin to verify that the correct components are properly installed. Thereafter, the inspection detailed must be performed at least once per month during the operating season.

As with any ride, perform a daily visual check for signs of loose, broken or missing parts.

All work must be performed by qualified personnel, capable of understanding the function of the parts and their proper installation. Use only those components authorized, specified or provided by Chance Rides Manufacturing, Inc. All applicable OSHA safety standards and safe industry practices must be observed.

Observe all safety information contained in the manufacturer's manuals. Make available this bulletin and all related technical information to personnel using the equipment.

Chance Rides Manufacturing, Inc. issues notifications for the benefit of owners of amusement rides manufactured by Chance Rides Manufacturing, Inc. As a service to the industry, and in the interest of employee and public safety, Chance Rides Manufacturing, Inc. also issues notifications for the benefit of owners of amusement ride equipment for which the manufacturer no longer exists, such as the Allan Herschell Company, Chance Manufacturing Co., Inc., Chance Rides, Inc., etc. In doing so, Chance Rides Manufacturing, Inc. does not assume liability for losses associated with amusement ride equipment built by manufacturers other than Chance Rides Manufacturing, Inc.



**CHANCE RIDES MANUFACTURING, INC.**  
4200 Walker  
Wichita, KS 67277-2328  
U.S.A.  
Phone: 1-316-942-7411 • FAX: 1-316-942-2012  
Website: [www.chancerides.com](http://www.chancerides.com)  
E-mail: [rides@chancerides.com](mailto:rides@chancerides.com)

Bulletin No:	B402CRM201-0
Release Date:	July 6, 2017
Effective Date:	July 6, 2017
Supersedes:	A402R1129-0 (Chance Rides, Inc., 6/25/93)
Completion Date:	See Text
Page:	2 of 3

Ride Manufacturer: CHANCE RIDES, INC.      Affected Production Dates: All

Ride Name: WIPEOUT      Affected Serial Nos.: All Units

Model No.: 402

Detail of Issue

**Monthly Inspection of Boom Pivot**

Refer to the following illustration for the inspection and maintenance of the boom pivot. This inspection must be performed monthly.

**NOTE:** Boom pivot bearings must be lubricated weekly in accordance with the WIPEOUT Maintenance Manual.

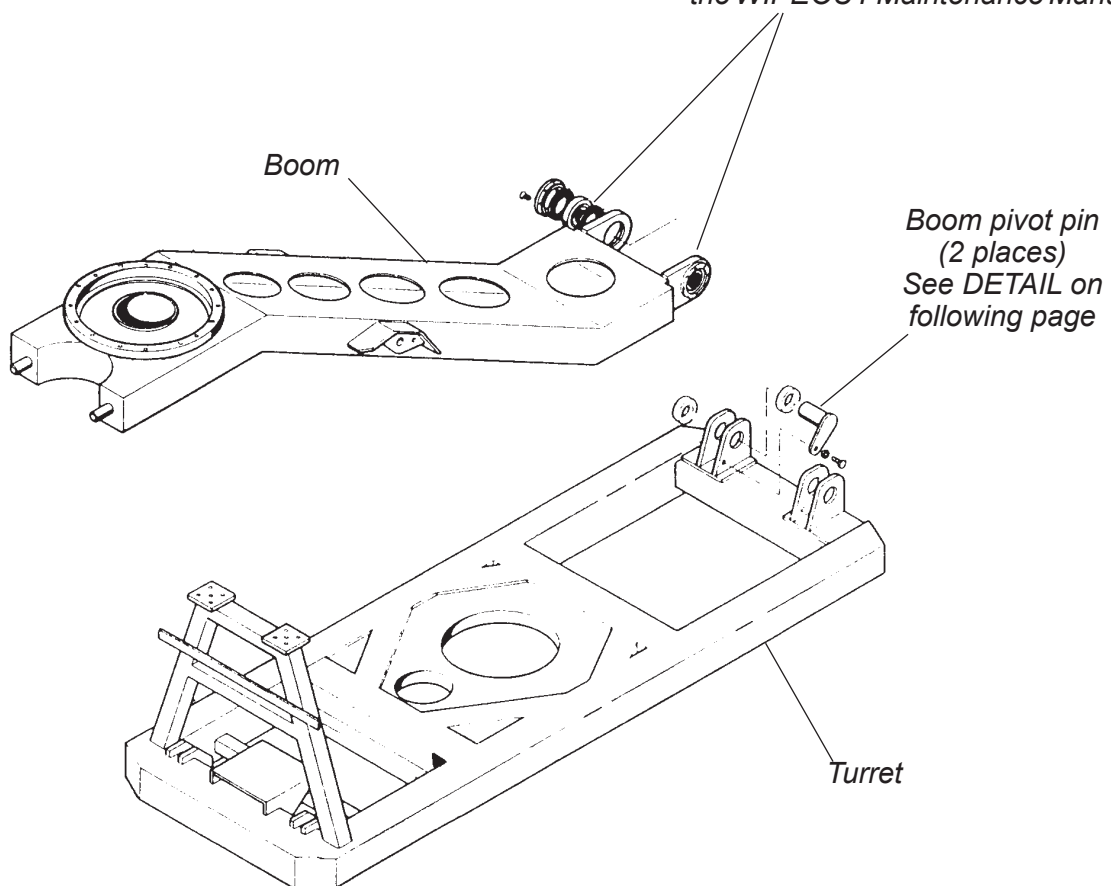



**CHANCE RIDES MANUFACTURING, INC.**  
**4200 Walker**  
**Wichita, KS 67277-2328**  
**U.S.A.**  
**Phone: 1-316-942-7411 • FAX: 1-316-942-2012**  
**Website: www.chancerides.com**  
**E-mail: rides@chancerides.com**

Bulletin No:	B402CRM201-0
Release Date:	July 6, 2017
Effective Date:	July 6, 2017
Supersedes:	A402R1129-0 (Chance Rides, Inc., 6/25/93)
Completion Date:	See Text
Page:	3 of 3

Ride Manufacturer: CHANCE RIDES, INC.

Affected Production Dates: All

Ride Name: WIPEOUT

Affected Serial Nos.: All Units

Model No.: 402

Detail of Issue (continued):

1. Inspect the boom pivot pin fasteners.
  - Each pin must be secured to the ears of the turret with a special locking capscrew as shown, with a retainer plate under the head of the capscrew. The locking capscrews are tightened to 50-60 foot-pounds when installed.
  - Check that the retainer plate is properly installed. The two tabs of the retainer plate must be bent down over the edges of the pin flange. The other tab must be bent against one of the capscrew flats to prevent it from turning.
2. Check the welded joint on the pin flange as shown for indications.
3. Check the flange on each boom pivot pin for bending or other distortion. This can indicate lateral movement of the pin.

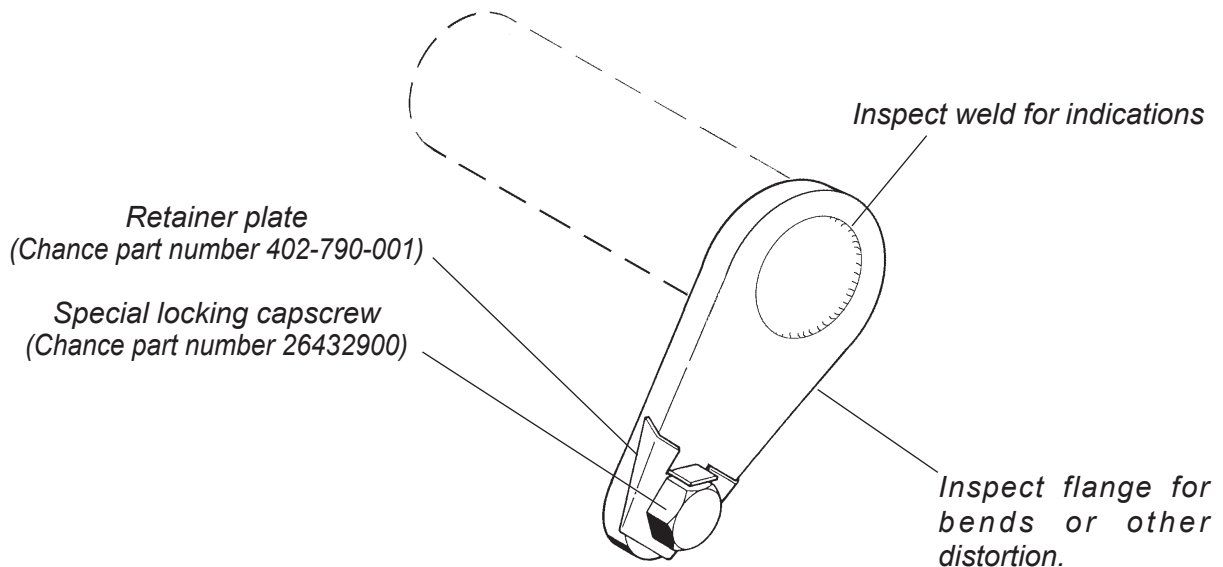

**IMPORTANT:** *Welding or alternate fasteners are not allowed.*