



CHANCE RIDES MANUFACTURING, INC.
4200 Walker
Wichita, KS 67277-2328
U.S.A.
Phone: 1-316-942-7411 • FAX: 1-316-942-2012
Website: www.rides.com
E-mail: rides@rides.com

Bulletin No:	B376CRM146-A
Release Date:	March 21, 2006
Effective Date:	March 21, 2006
Supersedes:	B376CRM146-0
Completion Date:	Immediately
Page:	1 of 5

SERVICE BULLETIN

Ride Manufacturer: CHANCE RIDES, INC.

Affected Production Dates: All

Ride Name: YO YO

Affected Serial Nos.: All Units

Model No.: 376

Abstract of Issue:

Sweep Lift Cylinder Bearing Inspection

Reason For Release:

Service bulletin B376CRM146-0 is superseded by this bulletin and is no longer in effect.

The sweeps on the YO YO connect to the sweep lift cylinder bearing assembly through the sweep links (the sweep lift cylinder bearing assembly is sometimes referred to as the “spider”). The bearing assembly is secured to the sweep lift cylinder rod by two lock nuts, and further secured by LocTite® and a bearing lock washer. If the sweep lift cylinder bearing assembly comes loose from the cylinder rod, the sweeps will lower, which can result in personal injury to the passengers.

The design of this area has not changed in over 35 years of production. To date, 95 YO YO amusement rides have been built using this design. Chance Rides Manufacturing, Inc. believes that this time-proven design is sound and the ride is safe if all aspects of the design are maintained per the manufacturer’s specification.

The sweep lift cylinder bearing assembly and its connection to the sweep lift cylinder must be periodically inspected to ensure that the parts are functioning properly and that the connection is secure.

*Sweep lift cylinder bearing assembly
(See cross-section view on page 3)*

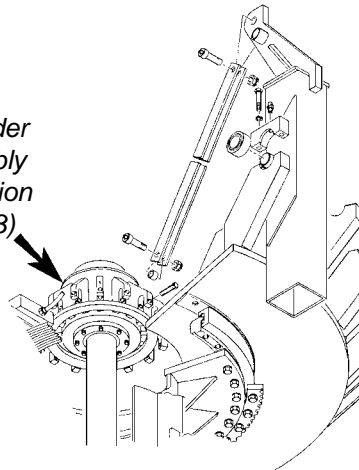

This service bulletin defines the procedure for inspection of the sweep lift cylinder bearing assembly and its connection to the sweep lift cylinder.



CHANCE RIDES MANUFACTURING, INC.
4200 Walker
Wichita, KS 67277-2328
U.S.A.
Phone: 1-316-942-7411 • FAX: 1-316-942-2012
Website: www.rides.com
E-mail: rides@rides.com

Bulletin No:	B376CRM146-A
Release Date:	March 21, 2006
Effective Date:	March 21, 2006
Supersedes:	B376CRM146-0
Completion Date:	Immediately
Page:	2 of 5

Ride Manufacturer: CHANCE RIDES, INC. Affected Production Dates: All

Ride Name: YO YO Affected Serial Nos.: All Units

Model No.: 376

Action to be Taken:

All owner/operators of YO YO amusement rides are required to inspect the sweep cylinder bearing assembly immediately upon receipt of this bulletin. The inspection procedure is provided on the following pages of this bulletin.

This inspection must be performed immediately upon receipt of this bulletin, then annually thereafter.

IF ANY VARIATIONS FROM THE CONDITIONS DESCRIBED IN THIS BULLETIN ARE FOUND, do not operate the ride. Contact the Customer Service Department at Chance Rides Manufacturing, Inc. immediately for instructions on the necessary repair procedure. **DO NOT ATTEMPT TO REPAIR THESE COMPONENTS EXCEPT AS SPECIFICALLY INSTRUCTED BY CHANCE RIDES MANUFACTURING, INC.**

IF THE CONDITION AND INSTALLATION OF THE SWEEP LIFT CYLINDER BEARING COMPONENTS ARE AS DESCRIBED, the ride can be operated normally.

All work must be performed by qualified personnel, capable of understanding the function of the parts and their proper installation. Use only those components authorized, specified or provided by Chance Rides Manufacturing, Inc. All applicable OSHA safety standards and safe industry practices must be observed.

Observe all safety information contained in the manufacturer's manuals. Make available this bulletin and all related technical information to personnel using the equipment.

Chance Rides Manufacturing, Inc. issues notifications for the benefit of owners of amusement rides manufactured by Chance Rides Manufacturing, Inc. As a service to the industry, and in the interest of employee and public safety, Chance Rides Manufacturing, Inc. also issues notifications for the benefit of owners of amusement ride equipment for which the manufacturer no longer exists, such as the Allan Herschell Company, Chance Manufacturing Co., Inc., Chance Rides, Inc., etc. In doing so, Chance Rides Manufacturing, Inc. does not assume liability for losses associated with amusement ride equipment built by manufacturers other than Chance Rides Manufacturing, Inc.



CHANCE RIDES MANUFACTURING, INC.
4200 Walker
Wichita, KS 67277-2328
U.S.A.
Phone: 1-316-942-7411 • FAX: 1-316-942-2012
Website: www.rides.com
E-mail: rides@rides.com

Bulletin No: B376CRM146-A
Release Date: March 21, 2006
Effective Date: March 21, 2006
Supersedes: B376CRM146-0
Completion Date: Immediately
Page: 3 of 5

Ride Manufacturer: CHANCE RIDES, INC.

Affected Production Dates: All

Ride Name: YO YO

Affected Serial Nos.: All Units

Model No.: 376

Detail of Issue (continued):

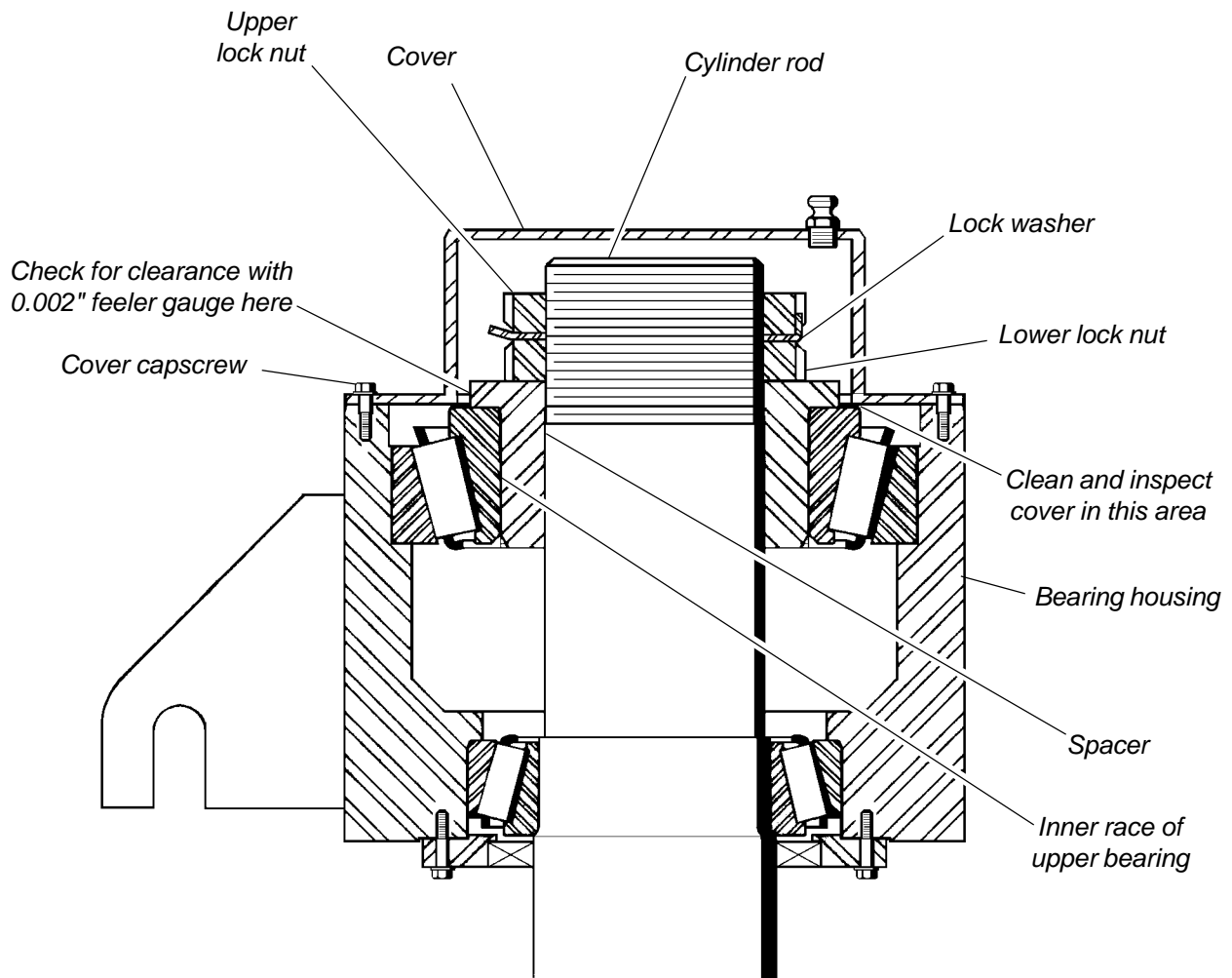

**Cross-Section of
Sweep Lift Cylinder Bearing Assembly**



CHANCE RIDES MANUFACTURING, INC.
4200 Walker
Wichita, KS 67277-2328
U.S.A.
Phone: 1-316-942-7411 • FAX: 1-316-942-2012
Website: www.rides.com
E-mail: rides@rides.com

Bulletin No:	B376CRM146-A
Release Date:	March 21, 2006
Effective Date:	March 21, 2006
Supersedes:	B376CRM146-0
Completion Date:	Immediately
Page:	4 of 5

Ride Manufacturer: CHANCE RIDES, INC. Affected Production Dates: All

Ride Name: YO YO Affected Serial Nos.: All Units

Model No.: 376

Detail of Issue (continued):

Inspection Procedure - Sweep Lift Cylinder Bearing Assembly

1. Remove the eight (8) capscrews which secure the cover to the bearing housing. Remove the cover.
2. Thoroughly clean cover in the area indicated in the illustration on page 3. Inspect the area for signs of wear, scratches, or other damage. If there is no sign of damage to the cover, proceed to the next step.
4. Clean the grease off of the cylinder rod and lock nuts to gain access to these parts for inspection.
5. Measure the cylinder rod protruding past the upper lock nut as shown on page 3. There must be 1/8" to 1/4" of the cylinder rod protruding past the upper lock nut (approximately 3 full threads). If this measurement is correct, proceed to the next step.
6. Check the upper lock nut for tightness as follows:
 - Do not bend the tab on the lock washer out of the slot in the upper lock nut.
 - Use a spanner wrench to turn the lock nut slightly in each direction. Do not use more than 50 ft-lbs. of force or the lock washer tab can be damaged.
 - Observe the slot with the bent lock washer tab for movement of the nut.If there is no movement of the lock nut, proceed to the next step.

**DO NOT BEND LOCK WASHER TAB
OUT OF SLOT IN UPPER LOCK NUT.**

*Look for movement of lock nut in relation
to bent tab on lock washer*

*Use a spanner wrench to turn
upper lock nut both directions.
DO NOT EXCEED 50 FT. LBS.*

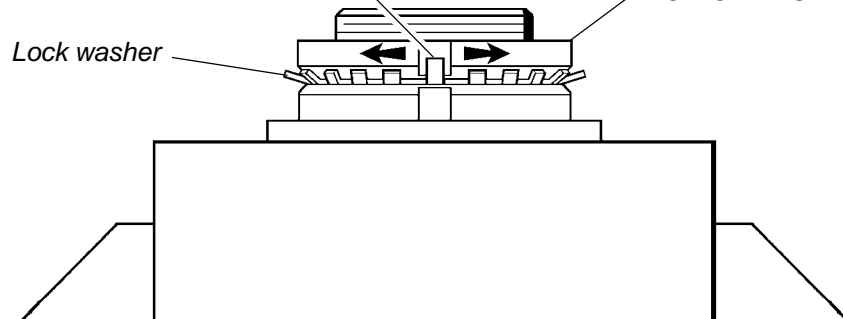



CHANCE RIDES MANUFACTURING, INC.
4200 Walker
Wichita, KS 67277-2328
U.S.A.
Phone: 1-316-942-7411 • FAX: 1-316-942-2012
Website: www.rides.com
E-mail: rides@rides.com

Bulletin No: B376CRM146-A
Release Date: March 21, 2006
Effective Date: March 21, 2006
Supersedes: B376CRM146-0
Completion Date: Immediately
Page: 5 of 5

Ride Manufacturer: CHANCE RIDES, INC. Affected Production Dates: All

Ride Name: YO YO Affected Serial Nos.: All Units

Model No.: 376

Detail of Issue (continued):

7. With the assistance of two helpers to MANUALLY rotate the sweeps as instructed in the Operation Manual. Observe the components from above while the ride is turning.



CAUTION: Movement of the ride while inspecting the sweep lift cylinder bearing assembly can cause loss of balance, which can result in personal injury. Use OSHA approved devices to secure the person to the ride structure until the inspection is completed.

DO NOT TURN THE RIDE BY ANY MEANS OTHER THAN MANUAL ROTATION FOR THIS PROCEDURE.

- The inner race of the upper bearing must remain stationary in relation to the cylinder rod.
 - The spacer must remain stationary in relation to the cylinder rod
 - Listen for any unusual noises from the bearing. Look for any unusual movement of any component.
8. Stop turning the ride. Use a 0.002" feeler gauge to look for clearance between the spacer and the inner race of the upper bearing as shown. Check this around the entire circumference of the spacer. There should be zero clearance at all locations.
 9. Apply silicone sealant to the flange on the cover and install it. Tighten the cover capscrews to 5-6 ft-lbs.

This inspection must be performed immediately upon receipt of this bulletin, then annually thereafter.