



**WISDOM
INDUSTRIES, Ltd.**

SERVICE BULLETIN

DATE: NOVEMBER 1, 2005
RIDE: LASER SHIP
**SUBJECT: SWEEP INSPECTION
PROCEDURE**
COMPLIANCE DATE: IMMEDIATE

- **THERE HAS BEEN ONE INSTANCE OF A SWEEP MIDDLE HINGE EAR FAILING DUE TO CORROSION.**
 1. **Inspect the ears shown in the attached drawing using magnetic flux testing for cracks at the hinge point and at the weldment to the sweep tube.**
 2. **If cracking is indicated at the pipe to ear weldment "V" the crack.**
 3. **Weld with 7018 Low Hydrogen rod.**
 4. **If cracking is indicated at the hinge point the ear must be replaced.**
 5. **Weld new ear with 7018 Low Hydrogen Rod.**

**If you have any questions contact Wisdom Industries, Ltd at
970-522-7515.**

- 1: REMOVE BOLT AND NUT.
- 2: MOVE LOWER SWEEP TO EXPOSE EARS.
- 3: MAGNAFLUX – INSPECT EARS FOR CRACKING.
- 4: REPLACE EARS IF CRACKING IS FOUND.
- 5: REASSEMBLE WITH NEW GRADE 5 BOLT AND ALL METAL LOCK NUT.

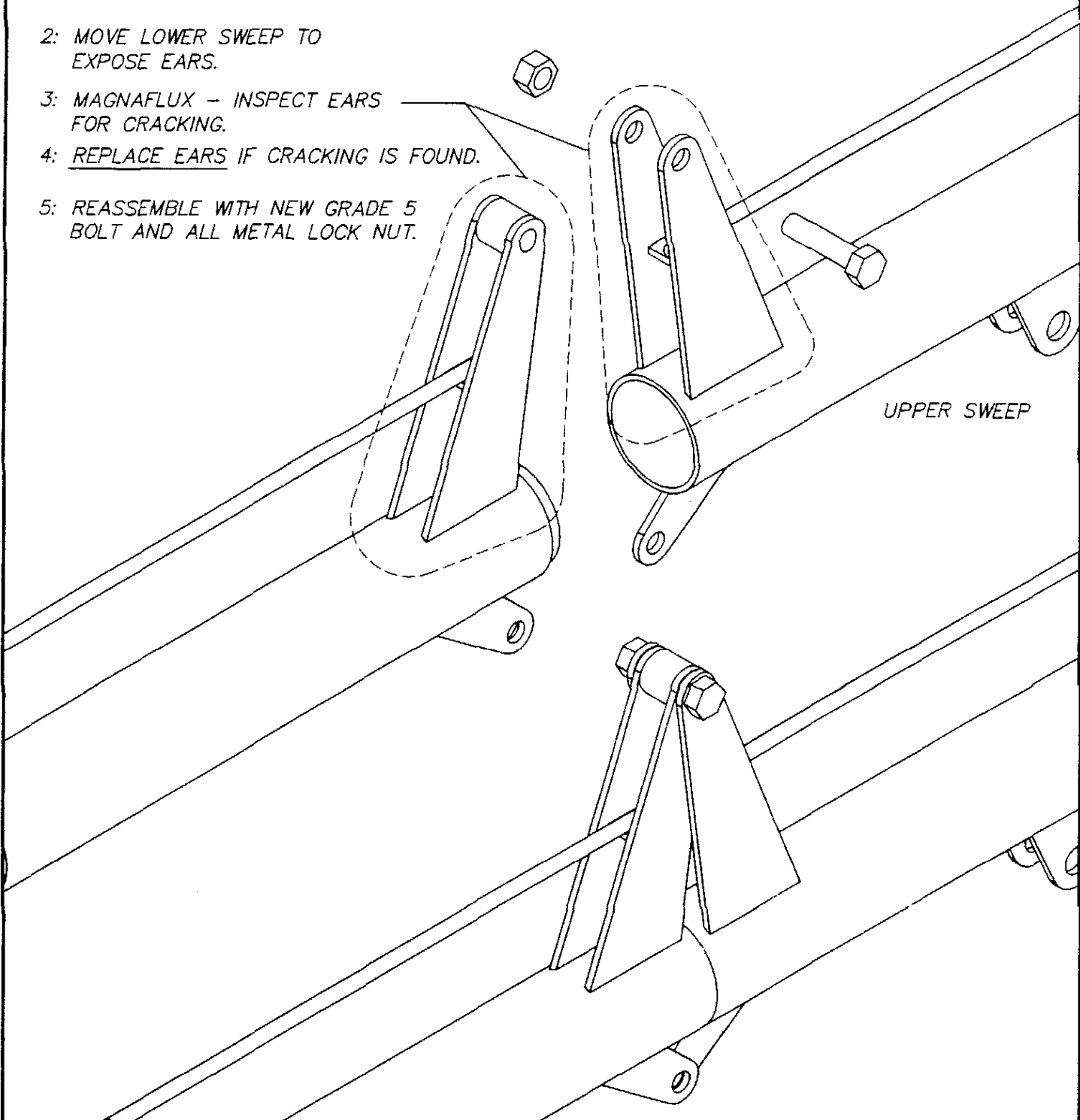

UPPER SWEEP

 **WISDOM INDUSTRIES** Merino, CO 80741

APPROVED BY:

DESCRIPTION: SWEEP INSPECTION PROCEDURE

SCALE: NTS
DATE: 10-31-05

EQUIPMENT: LASER SHIP

DRAWN BY: M.HICKAM

DRAWING NUMBER: SWEEP SAFTY

OCT 31, 2005 - 15:26:50 < L: \MISC RIDES\LASERS\JP\SWEEP SAFTY.DWG >